



TP2050

STEREO 50W (8Ω) POWER STAGE

Technical Information

Revision 1.0 – July 2005

GENERAL DESCRIPTION

The TP2050 is a stereo power stage capable of 50W continuous average power per channel, Class-T Digital Audio Power Amplifier using Tripath's proprietary Digital Power Processing™ technology. The TP2050 can be coupled with a Class-T controller such as TC2000 or TC2001 to produce a high quality stereo amplifier.

APPLICATIONS

- 5.1-Channel DVD
- Mini/Micro Component Systems
- Home Theater
- Stereo applications (6Ω / 8Ω)
- Mono applications (4Ω)

BENEFITS

- Single Supply Operation
- Very High Efficiency
- Wide Dynamic Range
- Compact layout

FEATURES

- Class-T Architecture
- High Output power
 - 35W @ 6Ω, < 1% THD+N
 - 50W @ 8Ω, < 3% THD+N
 - 117W @ 4Ω, < 10.0% THD+N (paralleled outputs)
- Audiophile Quality Sound
 - 0.007% THD+N @ 30W 8Ω
 - 0.005% THD+N @ 70W 4Ω (paralleled outputs)
- High Efficiency
 - 92% @ 60W 8Ω
 - 85% @ 46W 6Ω
 - 89% @ 117W 4Ω (paralleled outputs)
- Dynamic Range >100 dB

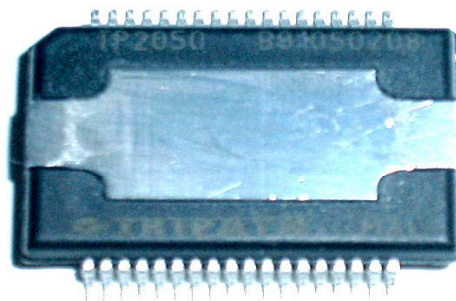

ABSOLUTE MAXIMUM RATINGS (Note 1)

| SYMBOL | PARAMETER | Value | UNITS |
|--------------------|--|------------|-------|
| V _{CC} | Power Supply | 40 | V |
| V _{logic} | Input Logic Level | 5.5 | V |
| T _A | Operating Free-air Temperature Range | 0 to 70 | °C |
| T _{STORE} | Storage Temperature Range | -40 to 150 | °C |
| T _{JMAX} | Maximum Junction Temperature | 150 | °C |
| ESD _{HB} | ESD Susceptibility – Human Body Model (Note 2), all pins | 2000 | V |

Note 1: Absolute Maximum Ratings indicate limits beyond which damage to the device may occur. See the table below for Operating Conditions.

Note 2: Human body model, 100pF discharged through a 1.5KΩ resistor.

OPERATING CONDITIONS

| SYMBOL | PARAMETER | MIN. | TYP. | MAX. | UNITS |
|-----------------|-----------------------------|------|------|------|-------|
| V _{CC} | Power Supply | 10 | | 36 | V |
| T _A | Operating Temperature Range | 0 | 25 | 70 | °C |

THERMAL CHARACTERISTICS

| SYMBOL | PARAMETER | Value | UNITS |
|-----------------|-------------------------------------|-------|-------|
| θ _{JC} | Junction-to-case Thermal Resistance | 2.5 | °C/W |

ELECTRICAL CHARACTERISTICS - TP2050

T_A = 25 °C. See Application/Test Circuit. Unless otherwise noted, the supply voltage is V_{CC} = 28V.

| SYMBOL | PARAMETER | CONDITIONS | MIN. | TYP. | MAX. | UNITS |
|-------------------|---|---|----------------------|------|----------------------|-------|
| I _q | Quiescent Current | V _{CC} = 28V, both channels switching | | 125 | | mA |
| I _{MUTE} | Tri-state Supply Current | V _{CC} = 31V | | 28 | | mA |
| V _{IH} | High-level input voltage IN1A, IN1B, IN2A, IN2B pins | PIN 23 = 2.7V PIN 23 = 3.3V PIN 23 = 5.0V | 1.65 1.95 2.80 | | | V |
| | High-level input voltage TRISTATE, PWRDN pins | PIN 23 = 2.7V PIN 23 = 3.3V PIN 23 = 5.0V | 1.50 1.70 1.85 | | | V |
| V _{IL} | Low-level input voltage IN1A, IN1B, IN2A, IN2B pins | PIN 23 = 2.7V PIN 23 = 3.3V PIN 23 = 5.0V | | | 1.05 1.35 2.2 | V |
| | Low-level input voltage TRISTATE, PWRDN pins | PIN 23 = 2.7V PIN 23 = 3.3V PIN 23 = 5.0V | | | 0.70 0.80 0.85 | V |
| I _{SC} | Short-circuit current limit | V _{CC} = 30V, T=25°C | 3.5 | 6 | 8 | A |

PERFORMANCE CHARACTERISTICS

$T_A = 25\text{ }^\circ\text{C}$. Unless otherwise noted, $V_{CC} = 30\text{V}$, $f=1\text{kHz}$, and the measurement bandwidth is 20kHz. The measurements assume connection to TC2000 or TC2001 Class-T controller.

| SYMBOL | PARAMETER | CONDITIONS | MIN. | TYP. | MAX. | UNITS |
|----------------|---|--|------|-------|------|---------------|
| P_{OUT} | Output Power (Continuous Average/Channel) (Note 13) | $V_{CC} = 30\text{V}$, $R_L = 8\Omega$ | | 35 | | W |
| | | THD+N = 0.01% | | 50 | | W |
| | | THD+N = 3.0% | | 60 | | W |
| | | THD+N = 10.0% | | | | |
| | | $V_{CC} = 23.5\text{V}$, $R_L = 6\Omega$ | | 25 | | W |
| | | THD+N = 0.01% | | 35 | | W |
| | | THD+N = 1.0% | | 45 | | W |
| THD + N | Total Harmonic Distortion Plus Noise | $P_{OUT} = 30\text{W/Channel}$, $R_L = 8\Omega$ | | 0.007 | | % |
| | | $V_{CC} = 30\text{V}$ | | | | |
| | | $P_{OUT} = 70\text{W Parallel}$, $R_L = 4\Omega$ | | 0.005 | | % |
| IHF-IM | IHF Intermodulation Distortion | 19kHz , 20kHz , 1:1 (IHF), $R_L = 8\Omega$ | | 0.05 | | % |
| | | $P_{OUT} = 30\text{W/Channel}$ | | | | |
| SNR | Signal-to-Noise Ratio | A-Weighted 0dB = 50W/Channel, $R_L = 8\Omega$ | | 103 | | dB |
| CS | Channel Separation | 0dB = 10W, $R_L = 8\Omega$, $f=1\text{kHz}$ | | 95 | | dB |
| A_V | Amplifier Gain | $P_{OUT} = 10\text{W/Channel}$, $R_L = 8\Omega$, See Application / Test Circuit | | 15 | | V/V |
| $A_{VELOCITY}$ | Channel to Channel Gain Error | $P_{OUT} = 10\text{W/Channel}$, $R_L = 8\Omega$ See Application / Test Circuit | | | 0.5 | dB |
| η | Power Efficiency | $P_{OUT} = 60\text{W/Channel}$, $R_L = 8\Omega$ | | 92 | | % |
| | | $P_{OUT} = 45\text{W/Channel}$, $R_L = 6\Omega$ | | 85 | | % |
| e_N | Output Noise Voltage | A-Weighted, input AC grounded, RFBC=14k Ω , RFBB=1k Ω | | 135 | | μV |

TP2050 POWER STAGE PIN DESCRIPTIONS

| Pin | Function | Description |
|-------|-----------|-----------------------------------|
| 1 | GND-SUB | Substrate ground |
| 35,36 | VccSign | Signal positive supply |
| 15 | Vcc1A | Positive supply |
| 12 | Vcc1B | Positive supply |
| 7 | Vcc2A | Positive supply |
| 4 | Vcc2B | Positive supply |
| 14 | GND1A | Negative supply |
| 13 | GND1B | Negative supply |
| 6 | GND2A | Negative supply |
| 5 | GND2B | Negative supply |
| 16,17 | OUT1A | Output half bridge 1A |
| 10,11 | OUT1B | Output half bridge 1B |
| 8,9 | OUT2A | Output half bridge 2A |
| 2,3 | OUT2B | Output half bridge 2B |
| 29 | IN1A | Input of half bridge 1A |
| 30 | IN1B | Input of half bridge 1B |
| 31 | IN2A | Input of half bridge 2A |
| 32 | IN2B | Input of half bridge 2B |
| 21,22 | Vdd | 5V regulator referenced to ground |
| 33,34 | Vss | 5V regulator referenced to Vcc |
| 25 | PWRDN | Stand-by pin |
| 26 | TRI-STATE | Hi-Z pin |
| 27 | FAULT | Fault output |
| 24 | CONFIG | Config input |
| 28 | TH-WAR | Thermal warning output |
| 19 | GND-clean | Logic ground |
| 23 | IBIAS | Logic threshold setting pin |
| 18 | NC | Not connected |
| 20 | GND-Reg | Ground for Vdd regulator |

TP2050 POWER STAGE PINOUT

(Top view with heat slug up)

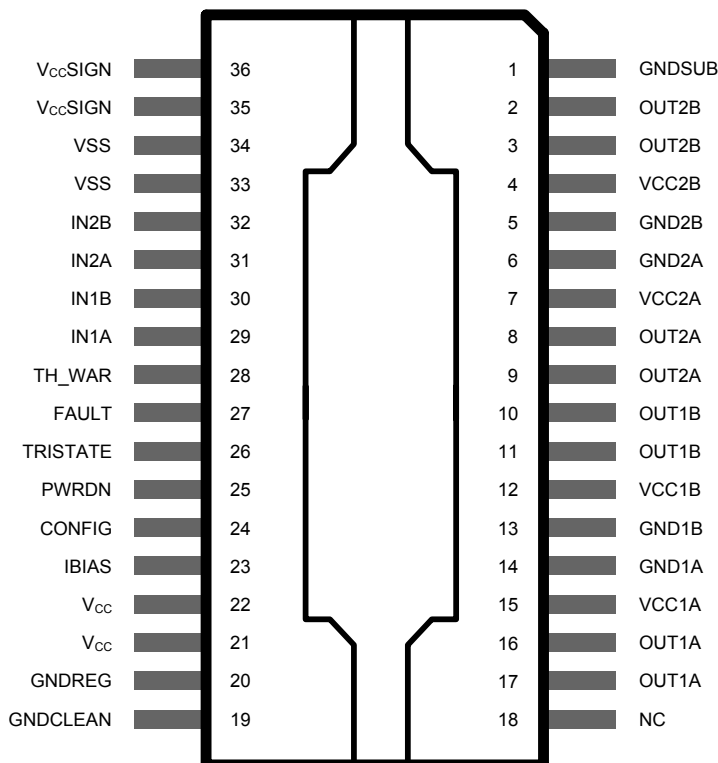

APPLICATION / TEST DIAGRAMS

Inputs and TC2000 / TC2001

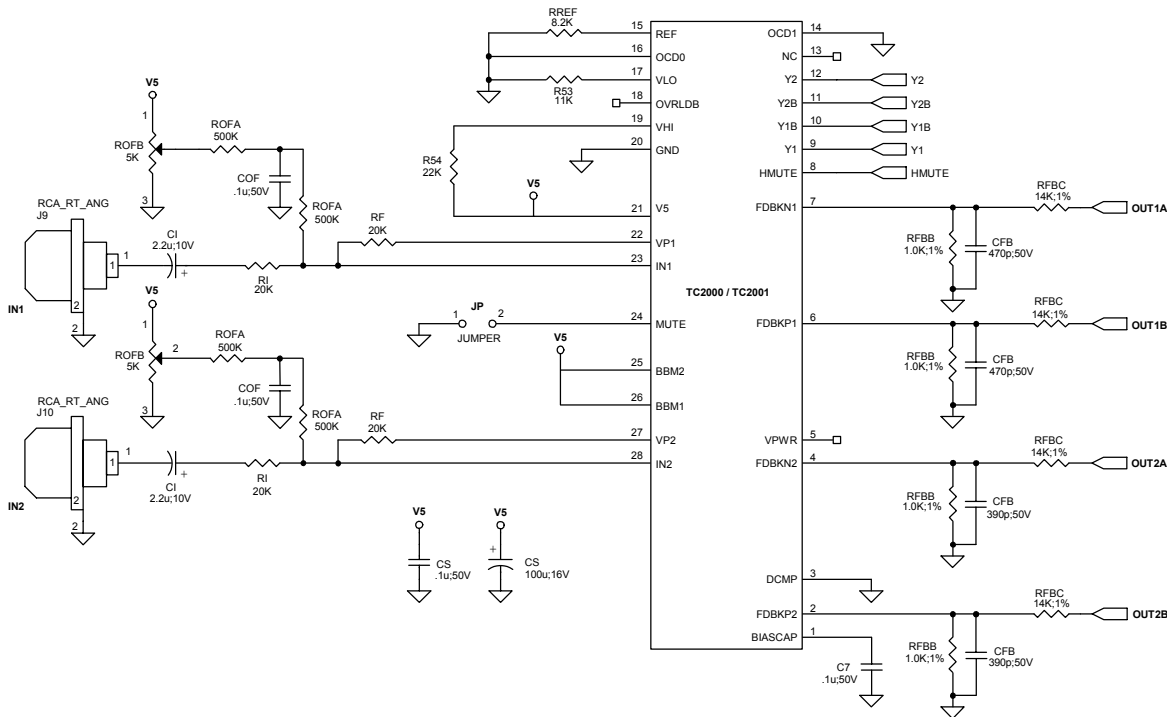

TP2050 and Outputs

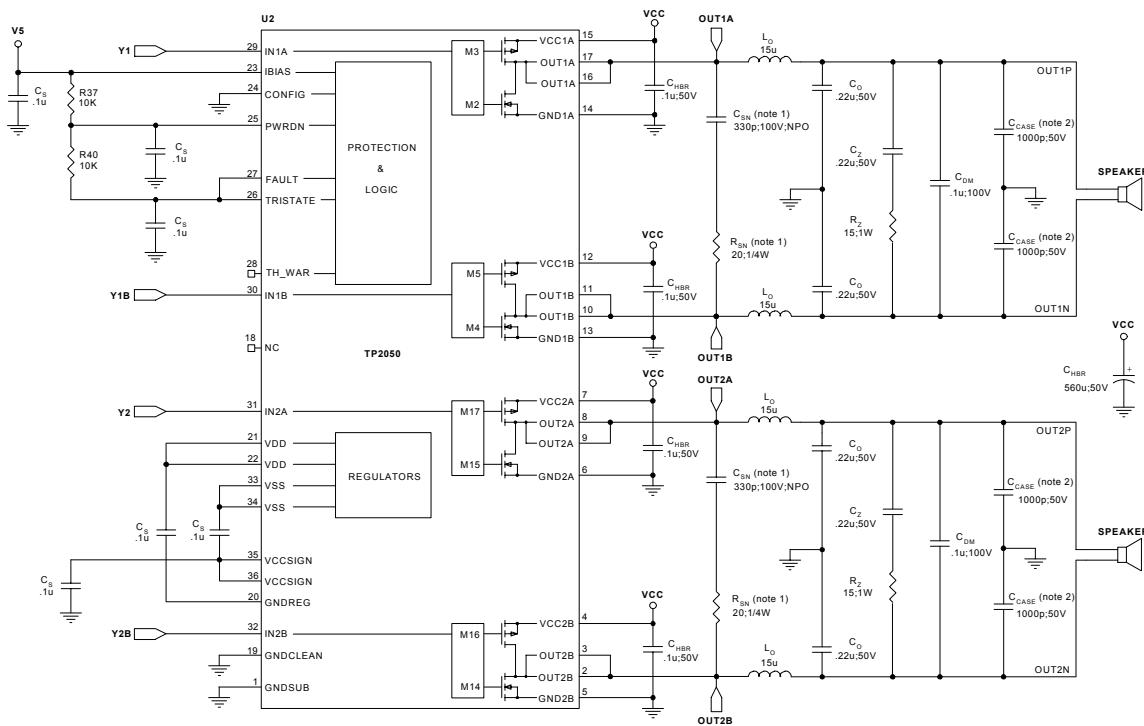

NOTE 1: C_{SN}/R_{SN} are optional locations, loaded only if required to reduce overshoot

NOTE 2: C_{CASE} (4 locations) represent bypass capacitors mounted at the exit of the speaker cable from the cabinet. They are optional and are used for EMI suppression. Lead lengths on these components must be kept short to be effective. They are shown in this schematic for reference.

APPLICATION / TEST DIAGRAMS FOR PARALLEL OPERATION

Inputs and TC2000 / TC2001

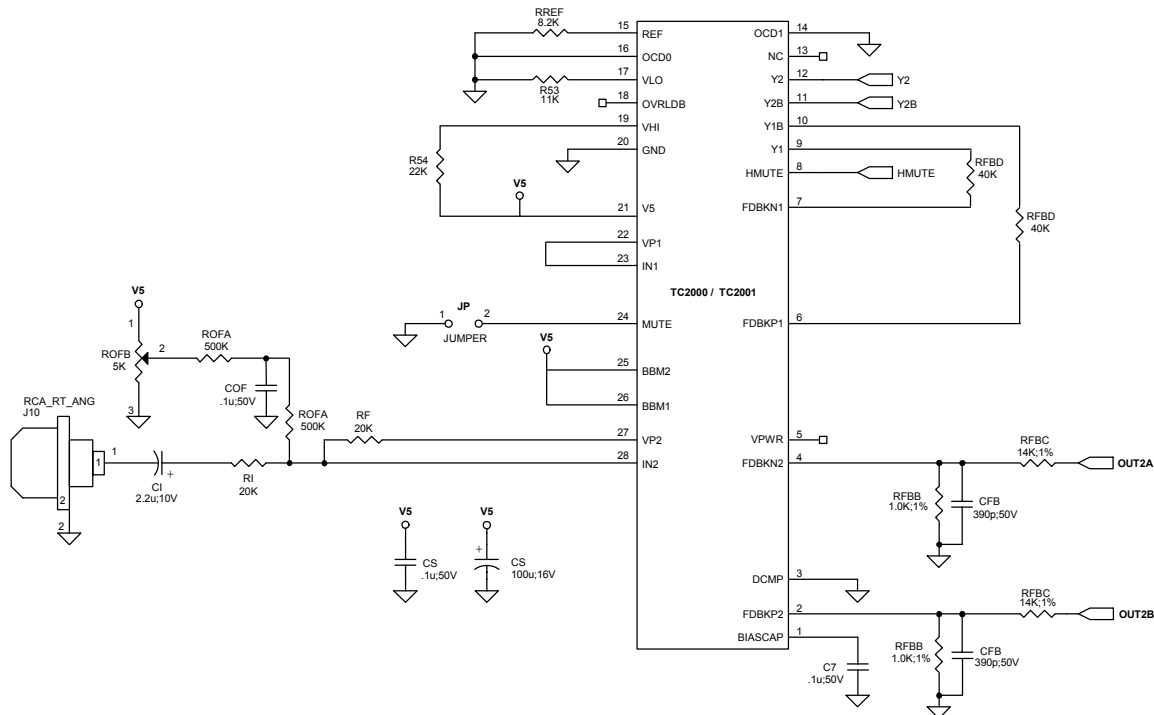

TP2050 and outputs

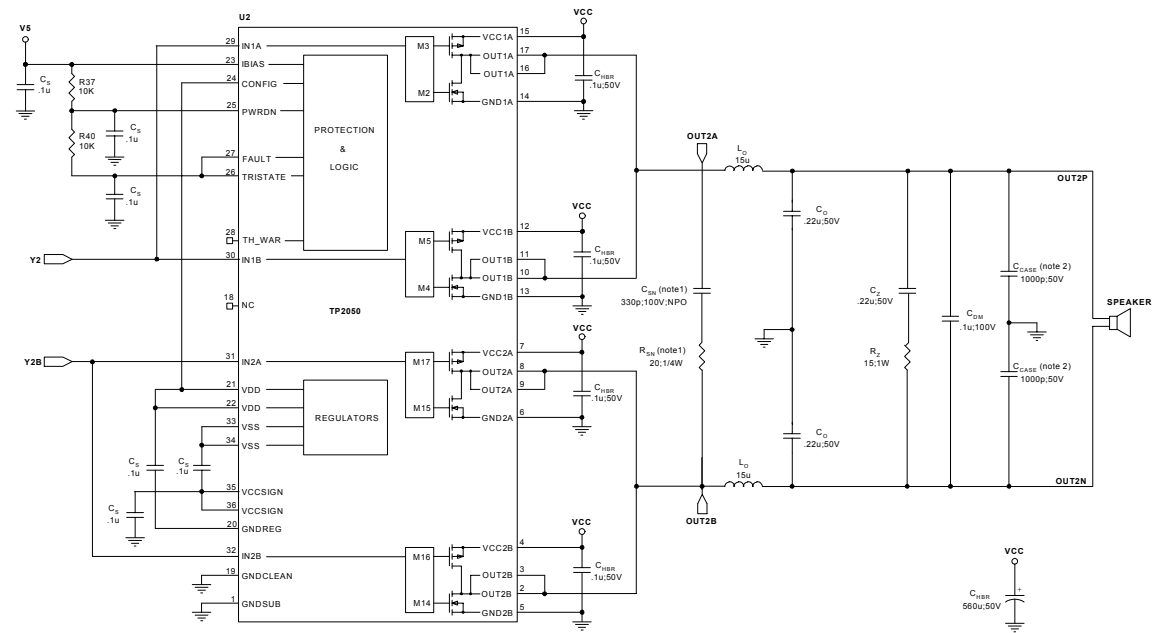

NOTE 1: C_{SN}/R_{SN} are optional locations, loaded only if required to reduce overshoot

NOTE 2: C_{CASE} (4 locations) represent bypass capacitors mounted at the exit of the speaker cable from the cabinet. They are optional and are used for EMI supression. Lead lengths on these components must be kept short to be effective. They are shown in this schematic for reference.

EXTERNAL COMPONENTS DESCRIPTION (Refer to the Application/Test Circuit)

| Component | Description |
|------------------|---|
| C _S | Supply decoupling for the power supply pins. For optimum performance, these components should be located close to the TC2000/TP2050 and returned to their respective ground as shown in the Application/Test Circuit. |
| C _Z | Zobel capacitor, which in conjunction with R _Z , terminates the output filter at high frequencies. Use a high quality film capacitor capable of sustaining the ripple current caused by the switching outputs. |
| R _Z | Zobel resistor, which in conjunction with C _Z , terminates the output filter at high frequencies. The combination of R _Z and C _Z minimizes peaking of the output filter under both no load conditions or with real world loads, including loudspeakers which usually exhibit a rising impedance with increasing frequency. The recommended power rating is 1 Watt. |
| L _O | Output inductor, which in conjunction with C _O , demodulates (filters) the switching waveform into an audio signal. Forms a second order filter with a cutoff frequency of $f_c = 1/(2\pi\sqrt{L_O C_O})$ and a quality factor of $Q = R_L C_O / \sqrt{L_O C_O}$. |
| C _O | Output capacitor, which in conjunction with L _O , demodulates (filters) the switching waveform into an audio signal. Forms a second order low-pass filter with a cutoff frequency of $f_c = 1/(2\pi\sqrt{L_O C_O})$ and a quality factor of $Q = R_L C_O / \sqrt{L_O C_O}$. Use a high quality film capacitor capable of sustaining the ripple current caused by the switching outputs. Electrolytic capacitors should not be used. |
| C _{HBR} | High-frequency bypass capacitor for V _{CC} – GND on each supply pin. A 50V rating is required for this component. |
| C _{SN} | Optional snubber capacitor, which in conjunction with R _{SN} , reduces overshoot on non-optimal layouts. Only required if switching output overshoot is above rated voltage of TP2500. Use low-dissipation type (NPO). |
| R _{SN} | Optional snubber resistor, which in conjunction with C _{SN} , reduces overshoot on non-optimal layouts. Only required if switching output overshoot is above rated voltage of TP2500. Required ¼ Watt rating. |
| C _{DM} | Differential mode capacitor. |

TYPICAL PERFORMANCE CHARACTERISTICS (in conjunction with TC2000 / TC2001)

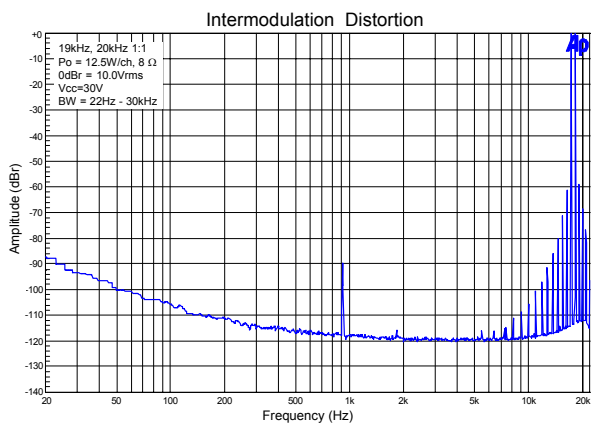
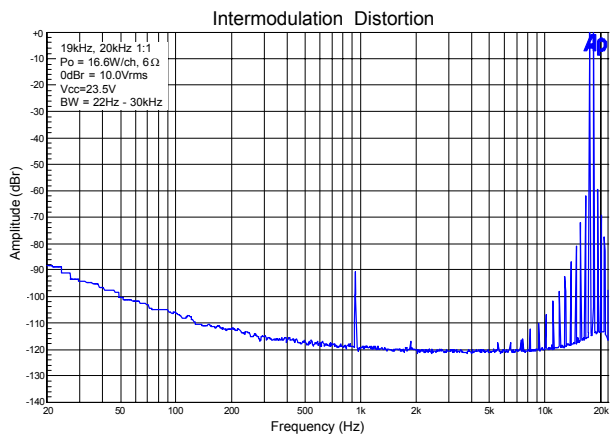
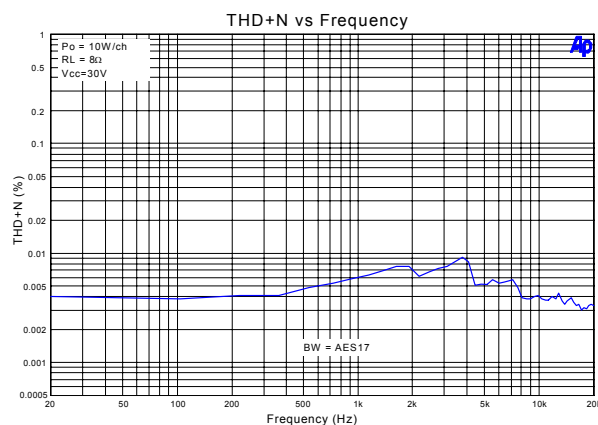
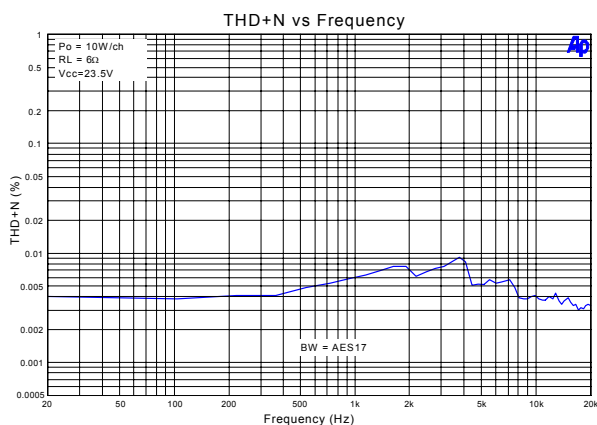
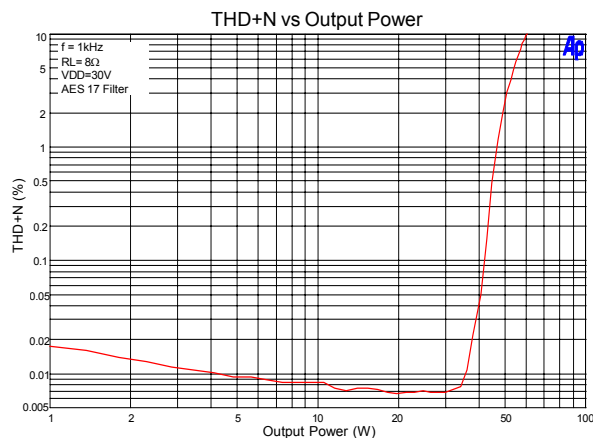
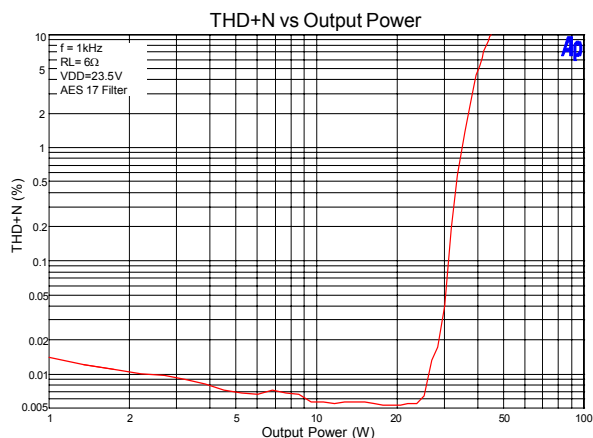

TYPICAL PERFORMANCE CHARACTERISTICS (cont'd)

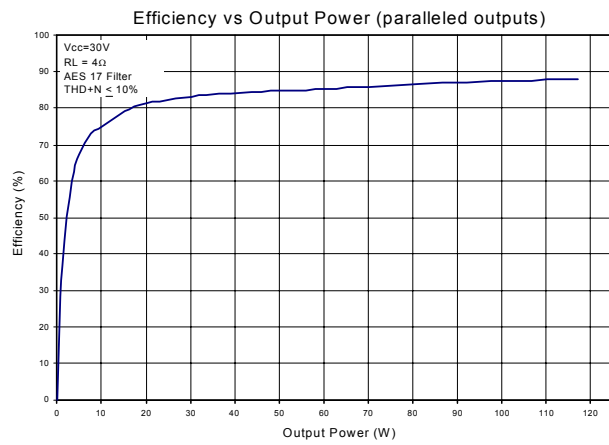
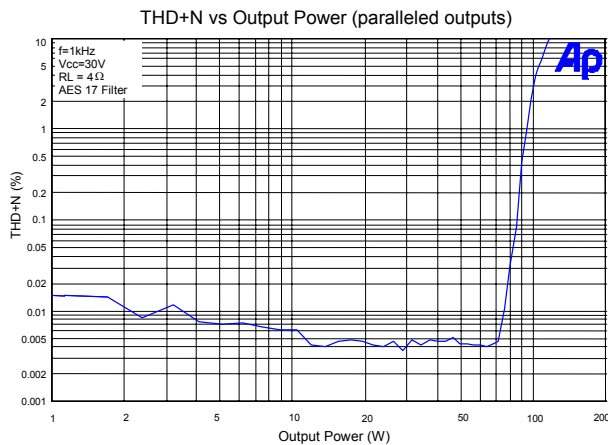
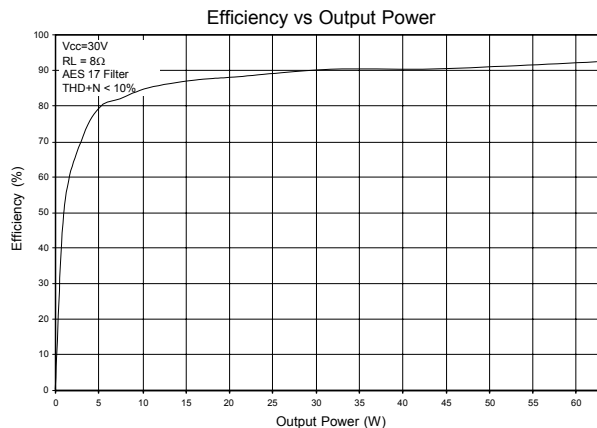
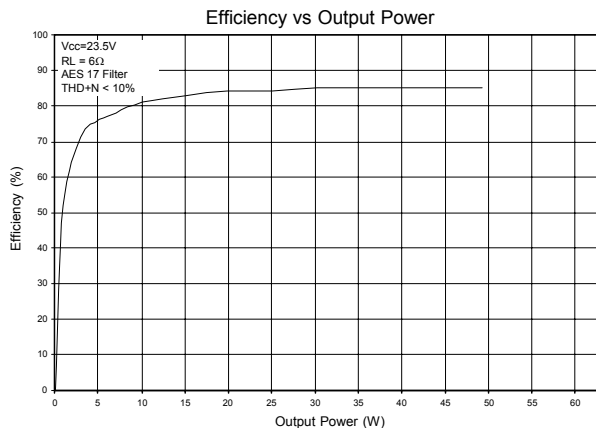

APPLICATION INFORMATION

Basic Operation

The TP2050 is a MOSFET output stage that level-shifts the signal processor's 5V switching patterns to the power supply voltages and drives the power MOSFETs. The power MOSFETs are complementary N-channel/P-channel devices configured in full-bridges and are used to supply power to the output load. The outputs of the power MOSFETs must be low pass filtered to remove the high frequency switching pattern. A residual voltage from the switching pattern will remain on the speaker outputs when the recommended output LC filter is used, but this signal is outside of the audio band and will not affect audio performance.

Circuit Board Layout

The TP2050 is a power (high current) power stage that operates at relatively high switching frequencies. The output of the amplifier switches between VCC and GND at high speeds while driving large currents. This high-frequency digital signal is passed through an LC low-pass filter to recover the amplified audio signal. Since the amplifier must drive the inductive LC output filter and speaker loads, the amplifier outputs can be pulled above the supply voltage and below ground by the energy in the output inductance. To avoid subjecting the TP2050 to potentially damaging voltage stress, it is critical to have a good printed circuit board layout. It is recommended that Tripath's layout and application circuit be used for all applications and only be deviated from after careful analysis of the effects of any changes.

The following components are important to place near their associated TP2050 pins and are ranked in order of layout importance, either for proper device operation or performance considerations.

- The capacitors C_{HBR} provide high frequency bypassing of the amplifier power supplies and will serve to reduce spikes across the supply rails. C_{HBR} should be kept within 1/8" (3mm) of the VCC pins. Please note that the four VCC pins must be decoupled separately. In addition, the voltage rating for C_{HBR} should be 50V as this capacitor is exposed to the full supply range. Similarly, capacitors C_S should be located as close as possible to their respective pins on the TP2050.

In general, to enable placement as close to the TP2050, and minimize PCB parasitics, the capacitors listed above should be surface mount types (with the exception of the bulk C_{HBR} capacitor).

TP2050 Output Capability

The TP2050 can drive two 8 Ohm loads with 40 Watts each at less than 0.05% THD+N. The maximum sustained amplifier output power will be determined by a number of factors including the TP2050 junction temperatures, the load impedance and the power supply voltage.

Tripath does not recommend driving loads below 6 Ohms single ended as the amplifier efficiency will be reduced and the amplifier will reach its current limit at relatively low power output levels. With the outputs connected in parallel, however, the TP2050 is capable of driving single channel loads down to 4 Ohms with very high power capability.

Paralleled Outputs

For stereo mode operation, the TP2050 is a dual full bridge. For parallel mode operation, the TP2050 can be configured as a single full bridge with double current capability by connecting the CONFIG pin to the VDD pin of the TP2050. Please refer to the Application/Test Diagram for parallel operation.

Output Filter Design

Tripath amplifiers generally have a higher switching frequency than PWM implementations, allowing the use of higher cutoff frequency filters and reducing the load dependent peaking/drooping in the 20kHz audio band. This is especially important for applications where the end customer may attach any speaker to the amplifier (as opposed to a system where speakers are shipped with the amplifier), since speakers are not purely resistive loads and the impedance they present changes over frequency and from speaker model to speaker model. An RC network, or “Zobel” (R_z , C_z) should be placed at the filter output to control the impedance “seen” by the TP2050 when not attached to a speaker load. The TP2050 works well with a 2nd order, 80kHz LC filter with $L_o = 10\mu\text{H}$ and $C_o = 0.47\mu\text{F}$ and $R_z = 10 \text{ Ohm}/1\text{W}$ and $C_z = 0.47\mu\text{F}$.

NOTE: Output inductor selection is a critical design step. The core material and geometry of the output filter inductor affects the TP2050 distortion levels, efficiency, power dissipation and EMI output. Please contact Tripath Applications for additional information about recommended inductor sources.

Protection Circuits

The TP2050 is protected against over-current, over / under-voltage and over-temperature conditions.

Over-temperature Protection

An over-temperature fault occurs if the junction temperature of the part exceeds approximately 150°C. The thermal hysteresis of the part is approximately 25°C, therefore the fault will automatically clear when the junction temperature drops below 125°C.

Performance Measurements of the TK2050

The TP2050 operates by generating a high frequency switching signal based on the audio input. This signal is sent through a low-pass filter (external to the Tripath amplifier) that recovers an amplified version of the audio input. The frequency of the switching pattern is spread spectrum in nature and typically varies between 100kHz and 1MHz, which is well above the 20Hz – 20kHz audio band. The pattern itself does not alter or distort the audio input signal, but it does introduce some inaudible components.

The measurements of certain performance parameters, particularly noise related specifications such as THD+N, are significantly affected by the design of the low-pass filter used on the output as well as the bandwidth setting of the measurement instrument used. Unless the filter has a very sharp roll-off just beyond the audio band or the bandwidth of the measurement instrument is limited, some of the inaudible noise components introduced by the TP2050 amplifier switching pattern will degrade the measurement.

One feature of the TP2050 is that it does not require large multi-pole filters to achieve excellent performance in listening tests, usually a more critical factor than performance measurements. Though using a multi-pole filter may remove high-frequency noise and improve THD+N type measurements (when they are made with wide-bandwidth measuring equipment), these same filters degrade frequency response. The TP2050 Evaluation Board uses the Application/Test Circuit of this data sheet, which has a simple two-pole output filter and excellent performance in listening tests. Measurements in this data sheet were taken using this same circuit with a limited bandwidth setting in the measurement instrument.

Package Information - TP2050

| DIM. | mm | | | inch | | |
|------|-----------|-------|------|-------|-------|-------|
| | MIN. | TYP. | MAX. | MIN. | TYP. | MAX. |
| A | 3.25 | | 3.5 | 0.128 | | 0.138 |
| A2 | | | 3.3 | | | 0.13 |
| A4 | 0.8 | | 1 | 0.031 | | 0.039 |
| A5 | | 0.2 | | | 0.008 | |
| a1 | 0 | | 0.1 | 0 | | 0.004 |
| b | 0.22 | | 0.38 | 0.008 | | 0.015 |
| c | 0.23 | | 0.32 | 0.009 | | 0.012 |
| D | 15.8 | | 16 | 0.622 | | 0.630 |
| D1 | 9.4 | | 9.8 | 0.37 | | 0.38 |
| D2 | | 1 | | | 0.039 | |
| E | 13.9 | | 14.5 | 0.547 | | 0.57 |
| E1 | 10.9 | | 11.1 | 0.429 | | 0.437 |
| E2 | | | 2.9 | | | 0.114 |
| E3 | 5.8 | | 6.2 | 0.228 | | 0.244 |
| E4 | 2.9 | | 3.2 | 0.114 | | 1.259 |
| e | | 0.65 | | | 0.026 | |
| e3 | | 11.05 | | | 0.435 | |
| G | 0 | | 0.1 | 0 | | 0.004 |
| H | 15.5 | | 15.9 | 0.61 | | 0.625 |
| h | | | 1.1 | | | 0.043 |
| L | 0.8 | | 1.1 | 0.031 | | 0.043 |
| N | 10° (max) | | | | | |
| s | 8° (max) | | | | | |

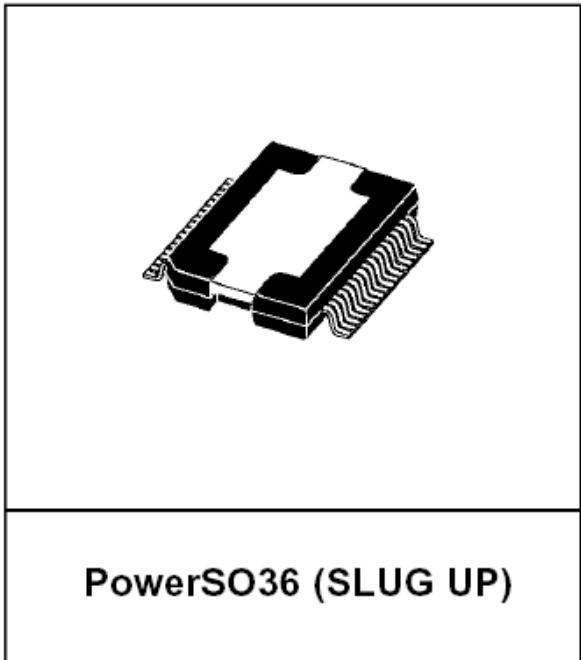

- (1) *D and E1* do not include mold flash or protusions.
Mold flash or protusions shall not exceed 0.15mm (0.006")
- (2) No intrusion allowed inwards the leads.

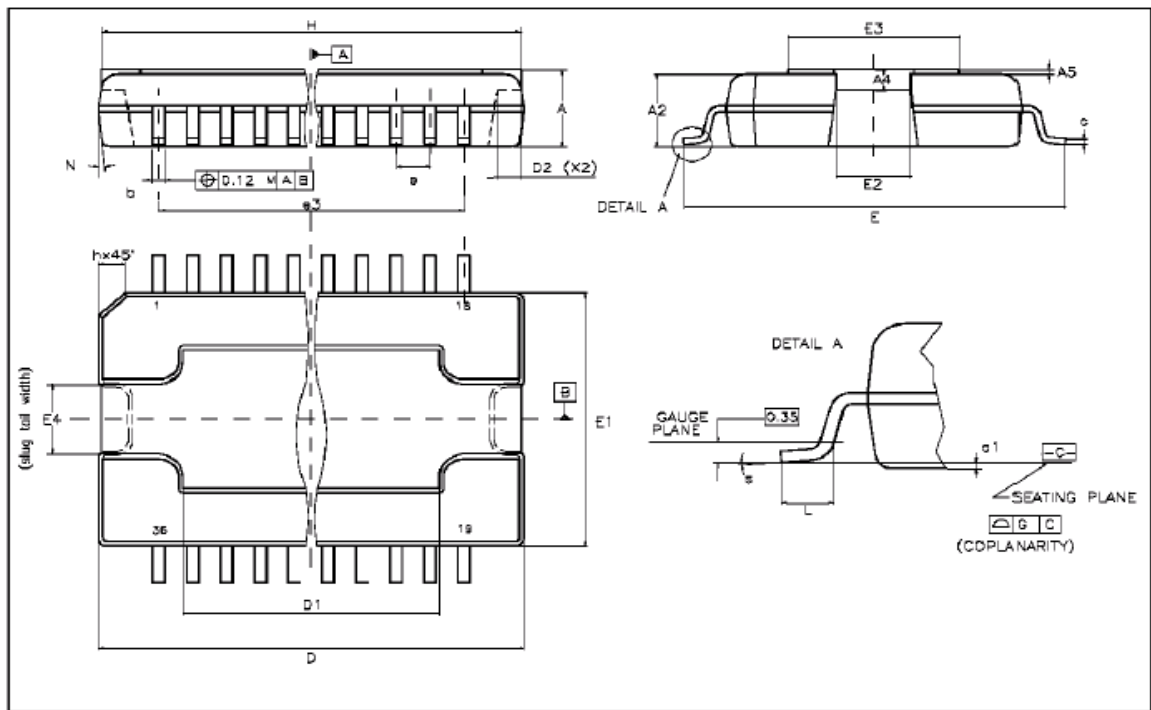

Tripath and Digital Power Processing are trademarks of Tripath Technology Inc. Other trademarks referenced in this document are owned by their respective companies.

Tripath Technology Inc. reserves the right to make changes without further notice to any products herein to improve reliability, function or design. Tripath does not assume any liability arising out of the application or use of any product or circuit described herein; neither does it convey any license under its patent rights, nor the rights of others.

TRIPATH'S PRODUCTS ARE NOT AUTHORIZED FOR USE AS CRITICAL COMPONENTS IN LIFE SUPPORT DEVICES OR SYSTEMS WITHOUT THE EXPRESS WRITTEN CONSENT OF THE PRESIDENT OF TRIPATH TECHNOLOGY INC. As used herein:

1. Life support devices or systems are devices or systems which, (a) are intended for surgical implant into the body, or (b) support or sustain life, and whose failure to perform, when properly used in accordance with instructions for use provided in this labeling, can be reasonably expected to result in significant injury to the user.
2. A critical component is any component of a life support device or system whose failure to perform can be reasonably expected to cause the failure of the life support device or system, or to affect its safety or effectiveness.

For more information on Tripath products, visit our web site at: www.tripath.com

Contact Information

TRIPATH TECHNOLOGY, INC

2560 Orchard Parkway, San Jose, CA 95131
408.750.3000 - P
408.750.3001 - F

For more Sales Information, please visit us @ www.tripath.com/contact.htm
For more Technical Information, please visit us @ www.tripath.com/data.htm